

LED PAR 30 LN DIMMABLE



FEATURES

- High performance LED chips
- Good replacement of PAR30 LN type Halogen and incandescent lamps
- Shock and vibration resistant design
- Instant on flicker free
- Contains no mercury



These led light bulbs are great in track lighting, canister and recessed fixtures. Use to replace 75 watt incandescent or 60w halogen floodlights and reduce energy use up to 75%

PRODUCT SPECIFICATION

- Energy used: 11w
- Light output: 800lm
- Rated life: 30,000hrs
- MOL: 112.50mm/4.43inches
- Diameter: 95.25mm/3.5inches
- Base:E27

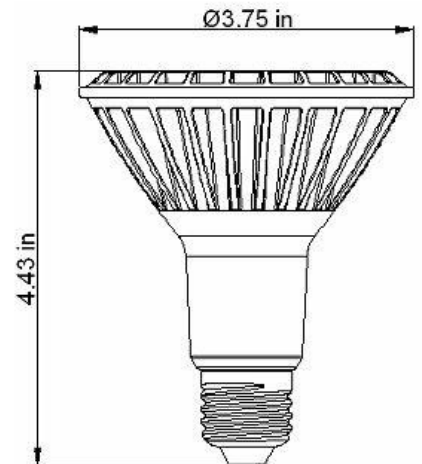
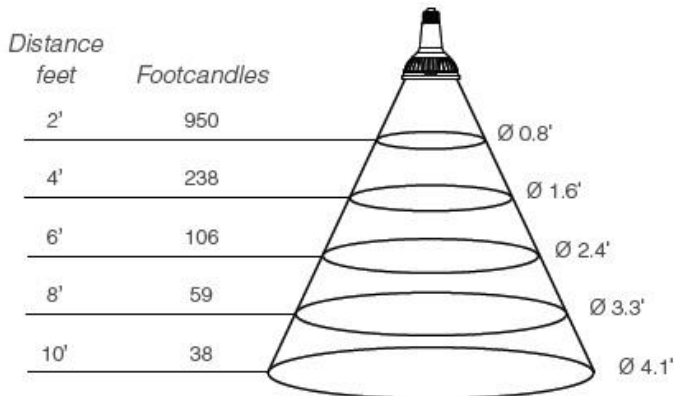

5220 N.W. 72nd Ave. Bays 30-35 Miami, FL 33166
Tel: 305-629-8122 Fax: 305-629-8121 Toll Free: 1-800-426-2577
Toll Free Fax: 1-800-355-3186
Website: www.excelites.com Email: excelltd@bellsouth.net