

SECTION A-A

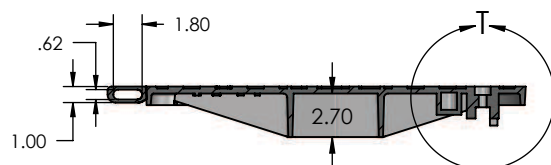

Sección B-B

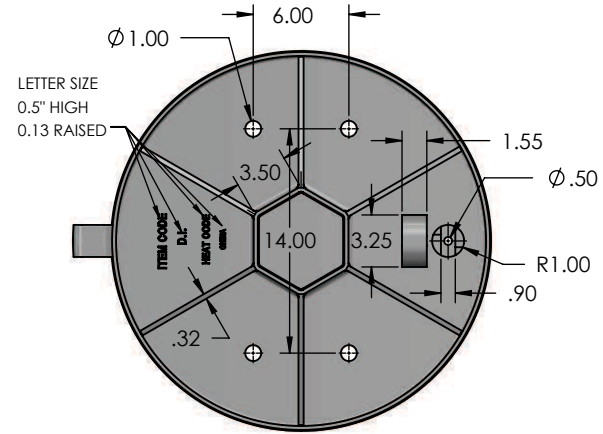
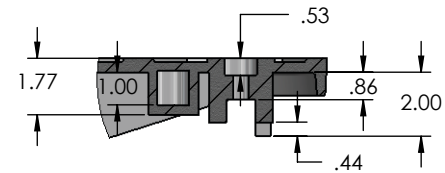

Detalle T
Escala 1 : 6

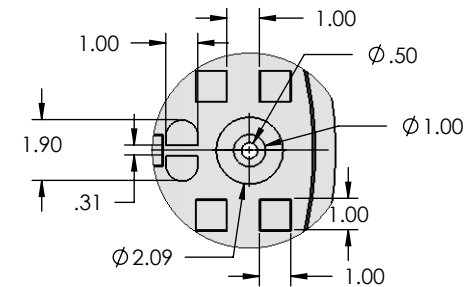

Detalle X
Escala 1 : 6

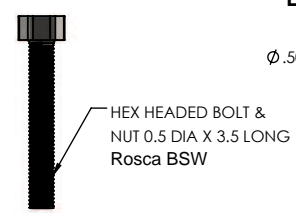
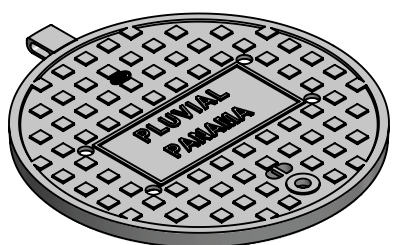

Perno de bisagra
(Material - Acero Inoxidable)

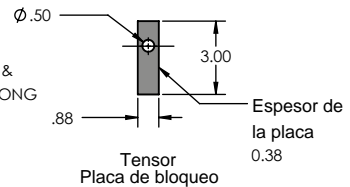

Tensor
Placa de bloqueo

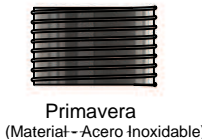

Primavera
(Material - Acero Inoxidable)

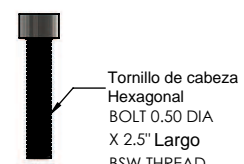

Perno de bloqueo
(Material - Acero Inoxidable)

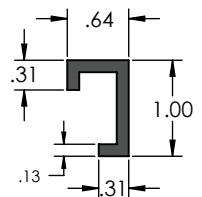

Junta de Goma
(Material - Neopreno)

CERTIFICACION DE PRUEBA DE CARGA (25 ton)

Approx. Wt.:	57 LBS	
Approx. Surf. Area.:	IN ²	
MATERIAL	Hierro Ductil por ASTM A536	
FINISH		
REV	Descripcion	Fecha
	REVISION	No Escala Dibujo

UNLESS OTHERWISE SPECIFIED: DIMENSIONS ARE IN INCHES		
TOLERANCES: FRACTIONAL: ±0.06 DECIMAL: ± 0.031 ANGLES: ±1° DRAFT ANGLES: 2°±1°		
DRAWN	NAME	DATE
	Mrrinal	06/22/17
COMMENTS: "PLUVIAL" MARKING		

Tapa Sola de 24" Panama		
SIP Industries/Serampore 2900 Patio Drive Houston, TX 77017 United States of America Ph: (713) 923-6111 Fax: (713) 923-6114		
SIZE	DWG. NO.	REV
A	17PA24CVRPL	
Escala : 1:12		Pagina 1 de 3

PROPRIETARY AND CONFIDENTIAL
 THE INFORMATION CONTAINED IN THIS DRAWING IS THE SOLE PROPERTY OF SIP INDUSTRIES/SERAMPORE. ANY REPRODUCTION IN PART OR AS A WHOLE WITHOUT THE WRITTEN PERMISSION OF SIP INDUSTRIES/SERAMPORE IS PROHIBITED.

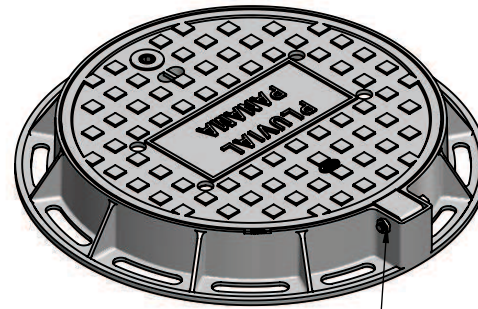
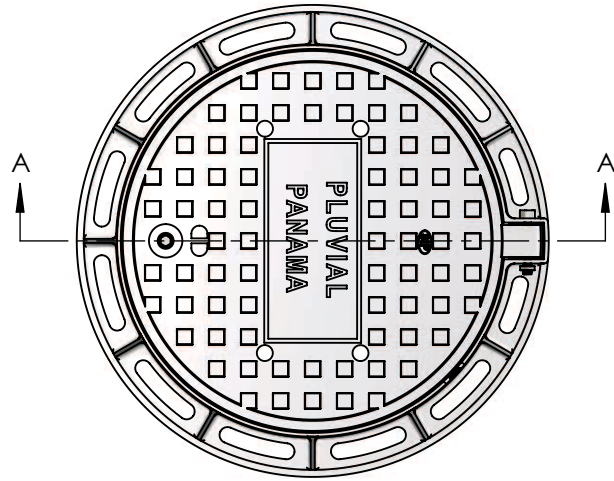

Tuerca Y Perno
Para mecanismo de bisagra

Bloqueo de tensor
para la disposicion
de bloqueo.

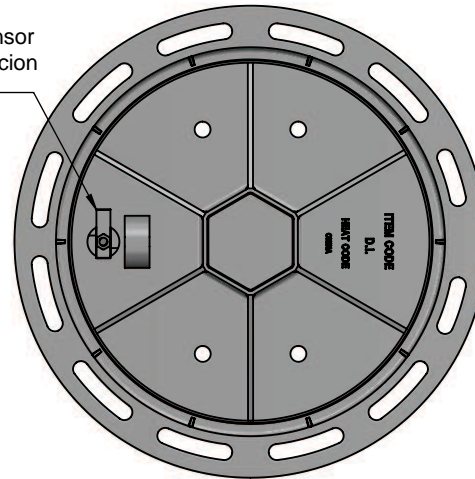

SPRING



Sección A-A

CERTIFICACION DE PRUEBA DE CARGA (25 ton)

PROPRIETARY AND CONFIDENTIAL
THE INFORMATION CONTAINED IN THIS DRAWING IS THE SOLE PROPERTY OF SIP INDUSTRIES/SERAMPORE. ANY REPRODUCTION IN PART OR AS A WHOLE WITHOUT THE WRITTEN PERMISSION OF SIP INDUSTRIES/SERAMPORE IS PROHIBITED.

Approx. Wt.:	96 LBS	
Approx. Surf. Area.:	IN²	
MATERIAL	Ductile Iron Per ASTM A536	
FINISH		
REV	Descripcion	Fecha
	REVISION	DO NOT SCALE DRAWING

UNLESS OTHERWISE SPECIFIED: DIMENSIONS ARE IN INCHES		
TOLERANCES: FRACTIONAL: ±0.06 DECIMAL: ± 0.031 ANGLES: ±1° DRAFT ANGLES: 2°±1°		
DRAWN	NAME	DATE
	Miral	06/22/17
COMMENTS:		

Tapa de 24" con Anillo Panama		
SIP Industries/Serampore  2900 Patio Drive Houston, TX 77017 United States of America Ph: (713) 923-6111 Fax: (713) 923-6114		
SIZE	DWG. NO.	REV
A	17PA24PL	
Escala 1:12		Pagina 3 de 3