

Sección A-A

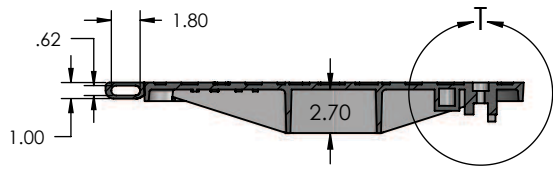

Sección B-B

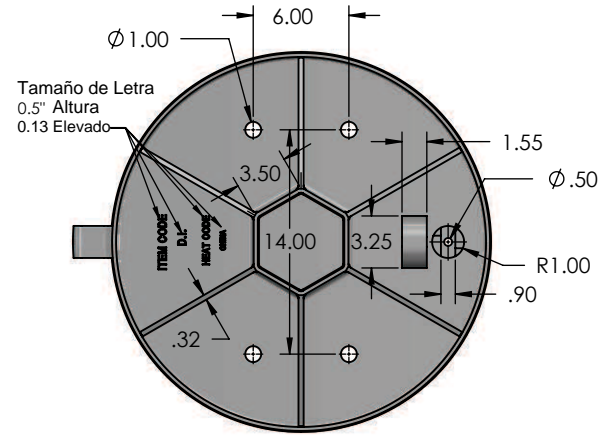
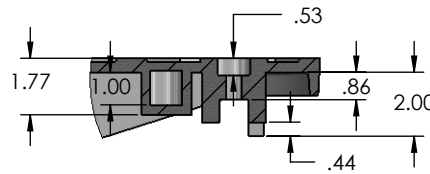

**Detalle T
Escala 1 : 6**

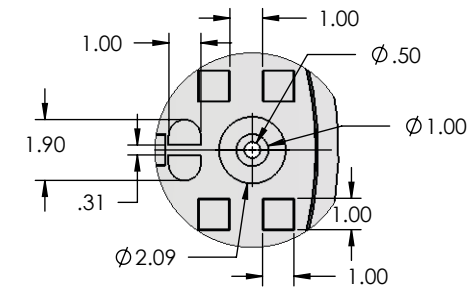

**Detalle X
Escala 1 : 6**

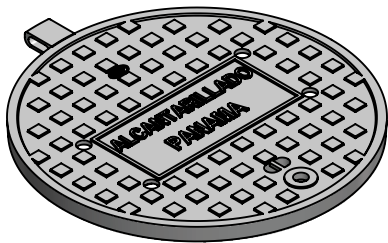

Perno de bisagra
(Material - Acero Inoxidable)



Tornillo de Cabeza Hexagonal
NUT 0.5 DIA X 3.5 Largo
Rosca BSW

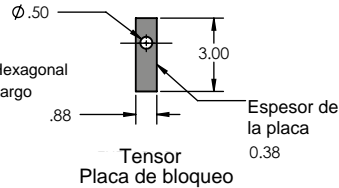

Tensor
Placa de bloqueo

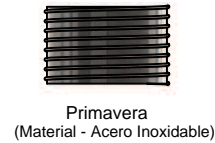

Primavera
(Material - Acero Inoxidable)



Allen cabeza Hexagonal
BOLT 0.50 DIA
X 2.5\"/>

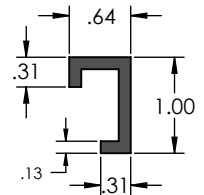

Junta de goma
(Material - Neopreno)

CERTIFICACION DE PRUEBA DE CARGA (25 ton)

PROPRIETARY AND CONFIDENTIAL
THE INFORMATION CONTAINED IN THIS DRAWING IS THE SOLE PROPERTY OF SIP INDUSTRIES/SERAMPORE. ANY REPRODUCTION IN PART OR AS A WHOLE WITHOUT THE WRITTEN PERMISSION OF SIP INDUSTRIES/SERAMPORE IS PROHIBITED.

			Peso Aproximado 57 LBS
			Approx. Surf. Area.: IN²
			MATERIAL
			Hierro Ductil por ASTM A536
			Terminar
			No Escala Dibujo
REV	Descripcion	Fecha	
	REVISION		

A menos Especificado:
Dimensiones son en pulgadas

TOLERANCES:		
FRACTIONAL:	±0.06	
DECIMAL:	± 0.031	
ANGLES:	±1°	
DRAFT ANGLES:	2°±1°	
DRAWN	NAME	DATE
	Mrrinal	06/22/17

COMMENTS:

Tapa Sola de 24" Panama

SIP Industries/Serampore

 2900 Patio Drive
 Houston, TX 77017
 United States of America
 Ph: (713) 923-6111 Fax: (713) 923-6114

SIZE	DWG. NO.	REV
A	17PANAMA24CVR	
Escala: 1:12		Página 1 de 3

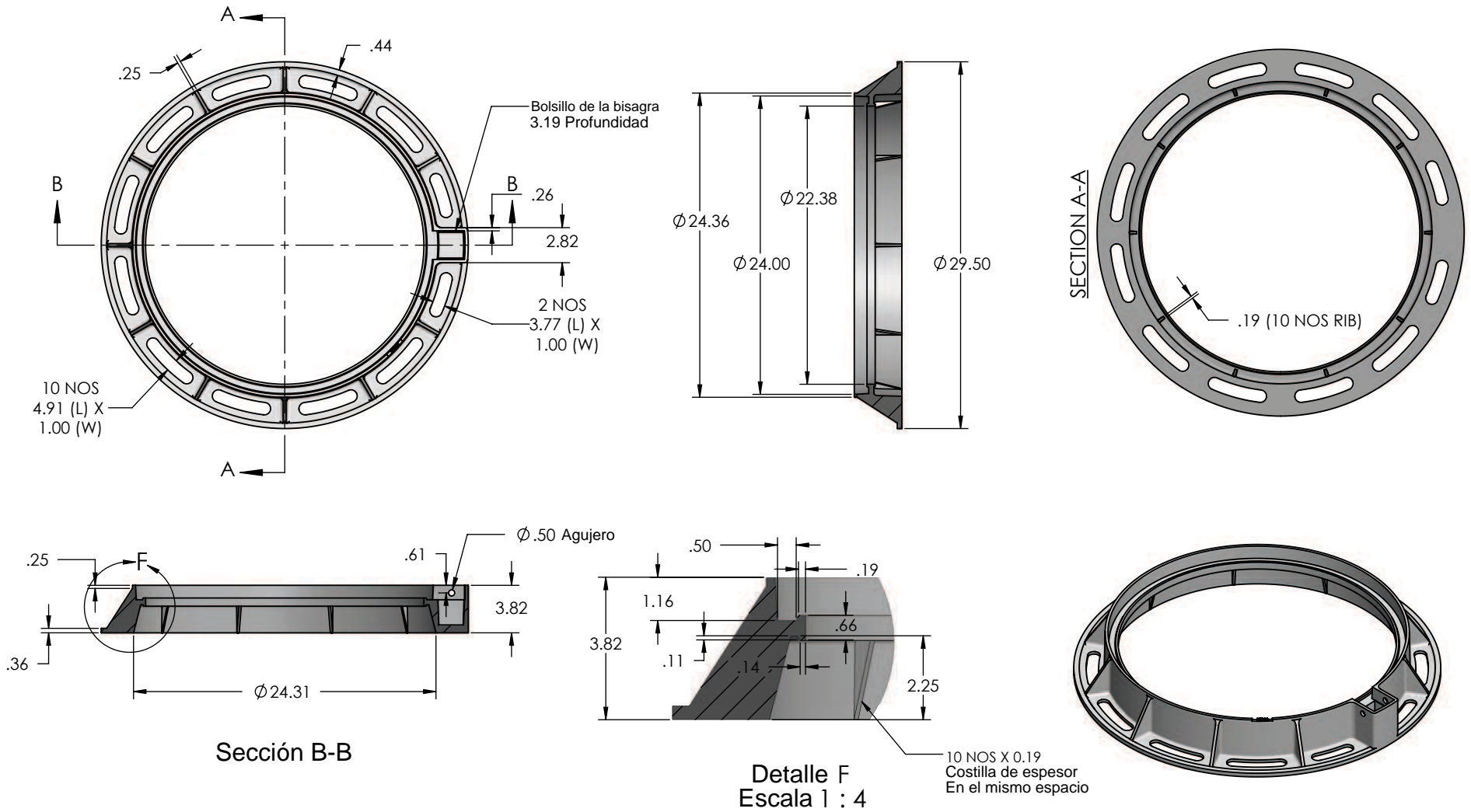

CERTIFICACION DE PRUEBA DE CARGA (25 ton)

PROPRIETARY AND CONFIDENTIAL
 THE INFORMATION CONTAINED IN THIS DRAWING IS THE SOLE PROPERTY OF SIP INDUSTRIES/SERAMPORE. ANY REPRODUCTION IN PART OR AS A WHOLE WITHOUT THE WRITTEN PERMISSION OF SIP INDUSTRIES/SERAMPORE IS PROHIBITED.

Approx. Wt.:	39 LBS	
Approx. Surf. Area.:	IN²	
MATERIAL	Ductile Iron Per ASTM A536	
FINISH		
DO NOT SCALE DRAWING		
REV	DESCRIPTION	DATE
REVISION		

UNLESS OTHERWISE SPECIFIED: DIMENSIONS ARE IN INCHES		
TOLERANCES: FRACTIONAL: ±0.06 DECIMAL: ± 0.031 ANGLES: ±1° DRAFT ANGLES: 2°±1°		
DRAWN	NAME	DATE
	Miral	06/22/17
COMMENTS:		

Anillo Panama Solo de 24"

SIP Industries/Serampore
 2900 Patio Drive
 Houston, TX 77017
 United States of America
 Ph: (713) 923-6111 Fax: (713) 923-6114

SIP

SIZE	DWG. NO.	REV
A	17PANAMA24R	

Escala: 1:12 Pagina 2 de 3

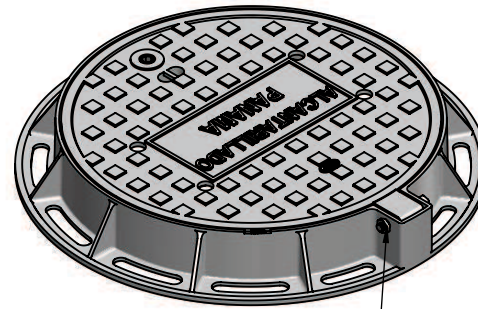
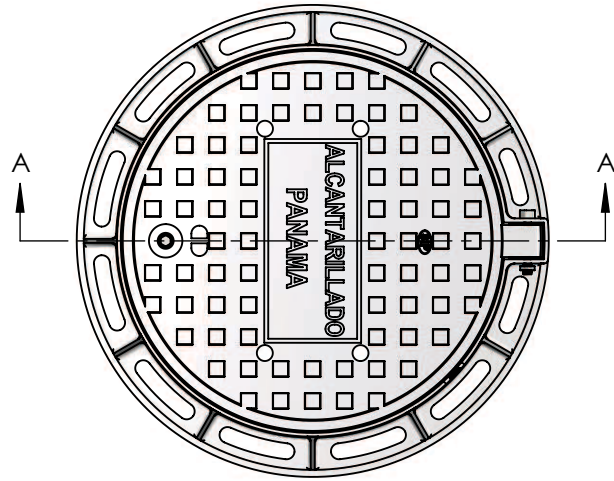

Tuerca Y Perno para mecanismo de bisagra

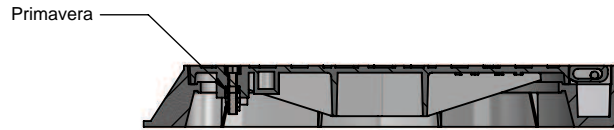

Sección A-A

Bloqueo de turnbuckle para el arreglo de bloqueo

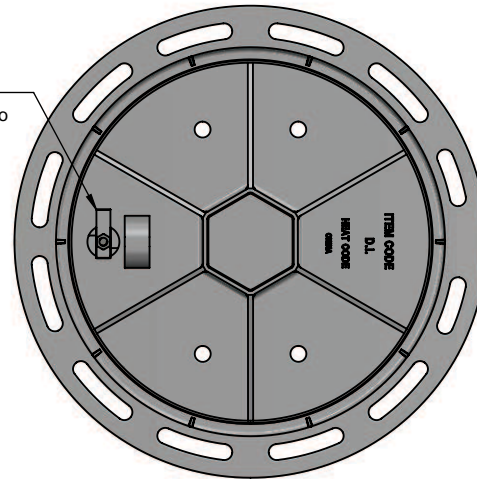

CERTIFICACION DE PRUEBA DE CARGA (25 ton)

UNLESS OTHERWISE SPECIFIED:
DIMENSIONS ARE IN INCHES

Tapa de 24" con Anillo Panama

Approx. Wt.: **96 LBS**

Approx. Surf. Area.: **IN²**

MATERIAL
Ductile Iron Per ASTM A536

FINISH

DO NOT SCALE DRAWING

TOLERANCES:
FRACTIONAL: ±0.06
DECIMAL: ± 0.031
ANGLES: ±1°
DRAFT ANGLES: 2°±1°

DRAWN	NAME	DATE
	Miral	06/22/17

COMMENTS:

SIP Industries/Serampore
 2900 Patio Drive
 Houston, TX 77017
 United States of America
 Ph: (713) 923-6111 Fax: (713) 923-6114

SIZE A	DWG. NO. 17PANAMA24	REV
------------------	-------------------------------	-----

Escala : 1:12

Pagina 3 de 3

PROPRIETARY AND CONFIDENTIAL

THE INFORMATION CONTAINED IN THIS DRAWING IS THE SOLE PROPERTY OF SIP INDUSTRIES/SERAMPORE. ANY REPRODUCTION IN PART OR AS A WHOLE WITHOUT THE WRITTEN PERMISSION OF SIP INDUSTRIES/SERAMPORE IS PROHIBITED.

REV	DESCRIPTION	DATE