

SECTION A-A

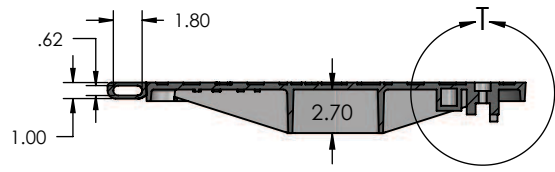

Sección B-B

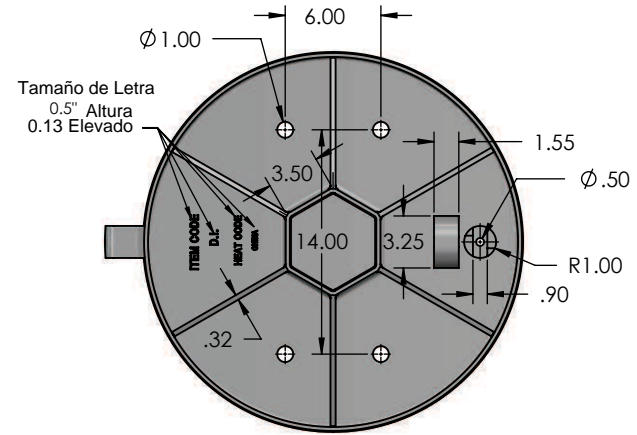
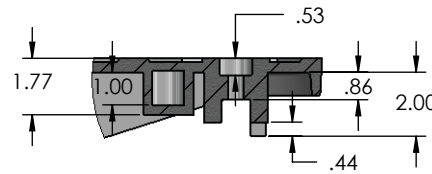

Detalle T
Escala 1 : 6

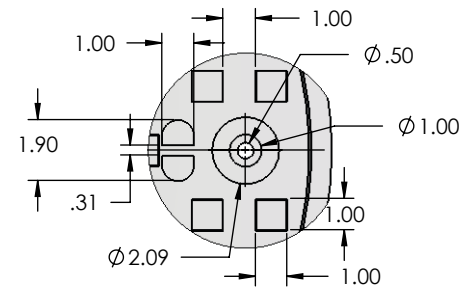

Detalle X
Escala 1 : 6

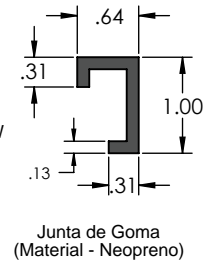
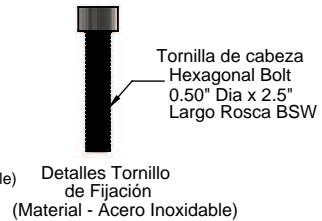
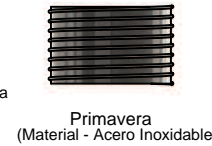
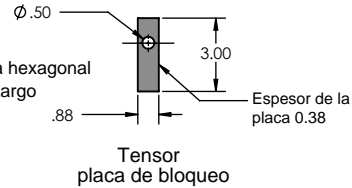
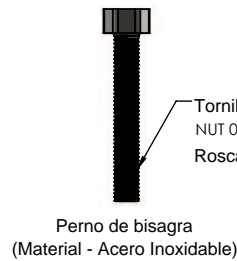
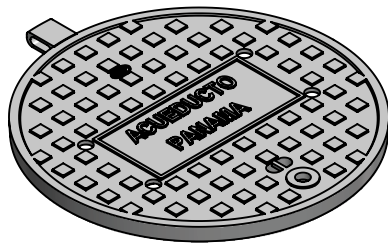

CERTIFICACION DE PRUEBA DE CARGA (25 ton)

PROPRIETARY AND CONFIDENTIAL
THE INFORMATION CONTAINED IN THIS DRAWING IS THE SOLE PROPERTY OF SIP INDUSTRIES/SERAMPORE. ANY REPRODUCTION IN PART OR AS A WHOLE WITHOUT THE WRITTEN PERMISSION OF SIP INDUSTRIES/SERAMPORE IS PROHIBITED.

			Peso Aproximado: 57 LBS
			Approx. Surf. Area.: IN²
			Material: Ductile Iron Per ASTM A536
			Terminar
REV	Descripcion	Fecha	
	REVISION		No Escala Dibujo

A Menos Especificado:
Dimensiones son en pulgadas

TOLERANCES:		
FRACTIONAL:	±0.06	
DECIMAL:	± 0.031	
ANGLES:	±1°	
DRAFT ANGLES:	2°±1°	
DRAWN	NAME	DATE
	Mirinal	06/22/17

Comentarios:

Tapa Sola de 24" Panama

SIP Industries/Serampore

 2900 Patio Drive
 Houston, TX 77017
 United States of America
 Ph: (713) 923-6111 Fax: (713) 923-6114

SIZE	DWG. NO.	REV
A	17PANAMA24CVR	
Escala: 1:12		Pagina 1 de 3

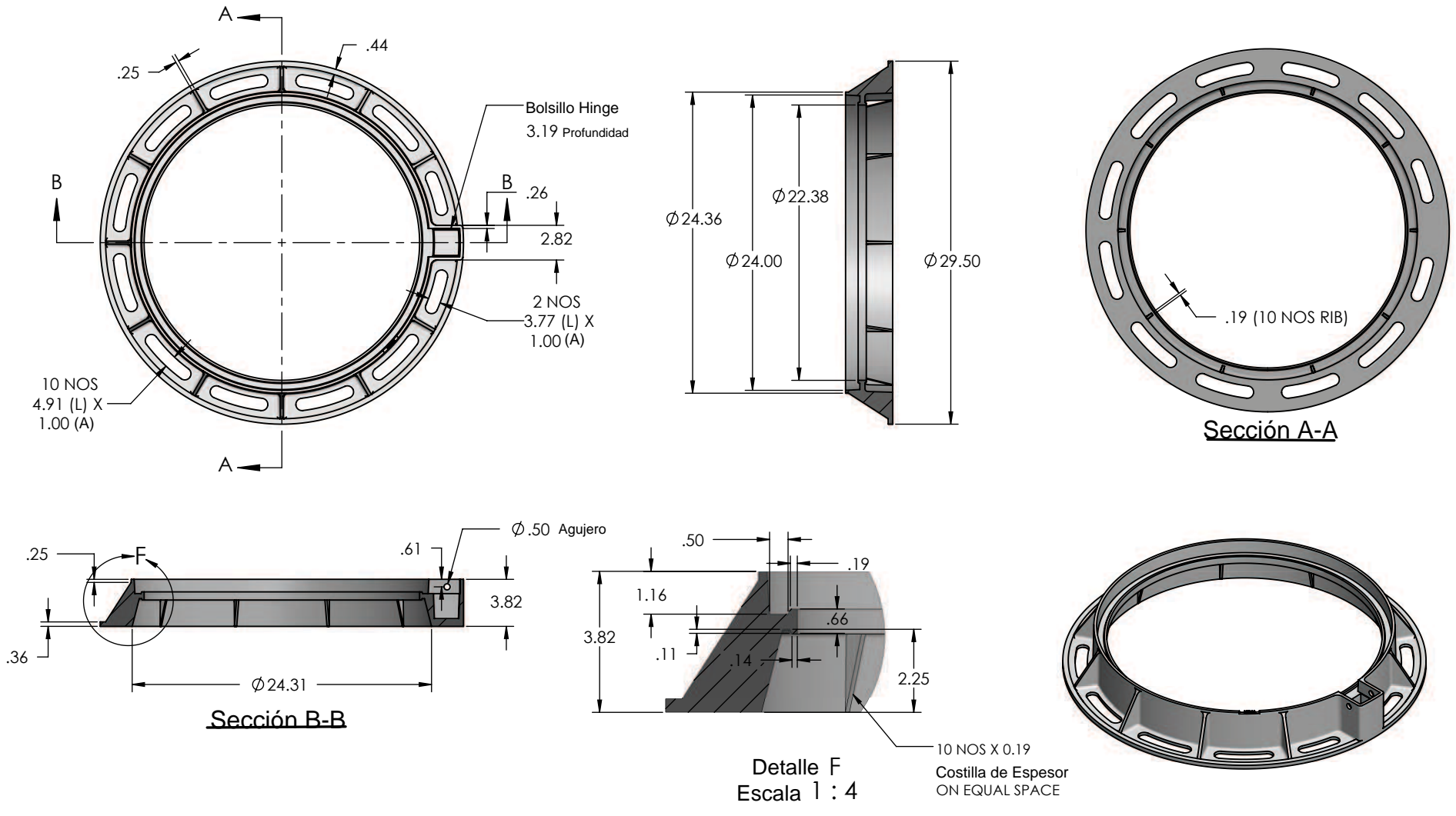

CERTIFICACION DE PRUEBA DE CARGA (25 ton)

UNLESS OTHERWISE SPECIFIED: DIMENSIONS ARE IN INCHES		Anillo Panama Solo de 24"	
TOLERANCES: FRACTIONAL: ±0.06 DECIMAL: ± 0.031 ANGLES: ±1° DRAFT ANGLES: 2°±1°		SIP Industries/Serampore 2900 Patio Drive Houston, TX 77017 United States of America Ph: (713) 923-6111 Fax: (713) 923-6114	
DRAWN	NAME Mrrinal	DATE 06/22/17	REV
COMMENTS:		SIZE A	DWG. NO. 17PANAMA24R
		Escala 1:12	Pagina 2 de 3

PROPRIETARY AND CONFIDENTIAL
 THE INFORMATION CONTAINED IN THIS DRAWING IS THE SOLE PROPERTY OF SIP INDUSTRIES/SERAMPORE. ANY REPRODUCTION IN PART OR AS A WHOLE WITHOUT THE WRITTEN PERMISSION OF SIP INDUSTRIES/SERAMPORE IS PROHIBITED.

Approx. Wt.:	39 LBS
Approx. Surf. Area.:	IN²
MATERIAL	Ductile Iron Per ASTM A536
FINISH	
DO NOT SCALE DRAWING	

REV	DESCRIPTION	DATE
	REVISION	

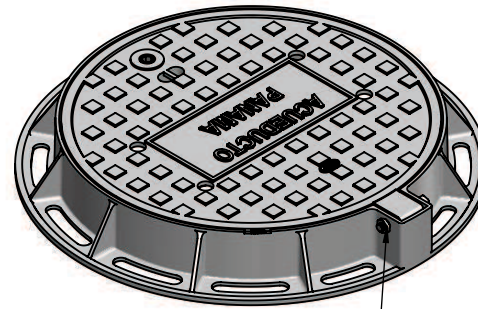
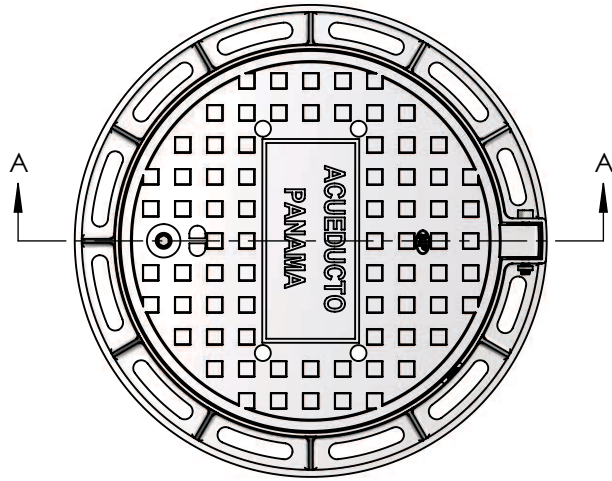

Tuerca Y Perno
FOR HING MECHANISM

Tensor
bloquear de
Arreglo de bloqueo

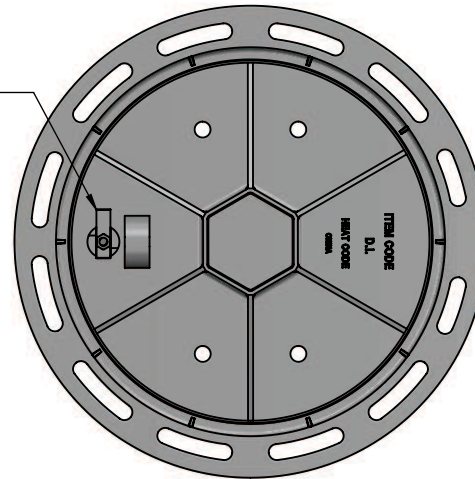

Primavera



Sección A-A

CERTIFICACION DE PRUEBA DE CARGA (25 ton)

PROPRIETARY AND CONFIDENTIAL
THE INFORMATION CONTAINED IN THIS DRAWING IS THE SOLE PROPERTY OF SIP INDUSTRIES/SERAMPORE. ANY REPRODUCTION IN PART OR AS A WHOLE WITHOUT THE WRITTEN PERMISSION OF SIP INDUSTRIES/SERAMPORE IS PROHIBITED.

Approx. Wt.:	96 LBS	
Approx. Surf. Area.:	IN²	
MATERIAL	Ductile Iron Per ASTM A536	
FINISH		
REV	DESCRIPTION	DATE
	REVISION	DO NOT SCALE DRAWING

UNLESS OTHERWISE SPECIFIED: DIMENSIONS ARE IN INCHES		
TOLERANCES: FRACTIONAL: ±0.06 DECIMAL: ± 0.031 ANGLES: ±1° DRAFT ANGLES: 2°±1°		
DRAWN	NAME	DATE
	Miral	06/22/17
COMMENTS:		

Tapa de 24" con Anillo Panama

SIP Industries/Serampore

 2900 Patio Drive
 Houston, TX 77017
 United States of America
 Ph: (713) 923-6111 Fax: (713) 923-6114

SIZE	DWG. NO.	REV
A	17PANAMA24	
SCALE: 1:12		Pagina 3 de 3